

HSE ROHS

REV	ECN NO	DESCRIPTION	DATE	NAME
A		NEW		

Specifications

1. Current Rating: 1Amps
2. Contact Resistance: 20mΩ
3. Insulator Resistance: 1000 Megohms min.
4. Dielectric withstanding Voltage: AC/DC 500V
5. Operating Temperature: -40°C to +105°C
6. Contact Material: phosphor Bronze
7. Insulator Material: Asfollows
8. Plated: Asfollows

Ordering Information

L302 XX-XX 2 X XX X

Insulation Height*Width (H*W)	NO. of Pins Per Row	Material	Contact Plating	Serial NO.	Packing
Option: 20=2.0*2.5	1-50P	1=PPB	0=0.8° Gold	01-69 (No pillars)	A=PE Bag
		2=PPS	1=Au1° Gold	70-89 (pillars)	B=Tube
		3=NY6T	2=Au1.5° Gold	90-99 (outside pillars)	C=Tray
		4=LCP	3=Au2° Gold		D=Reel
		5=NY66	4=Au3° Gold		
		6=Customized	5=Au5° Gold		
		7=NY46	6=Customized		
		8=NY9T	7=Gold/Tin		
			8=Tin		

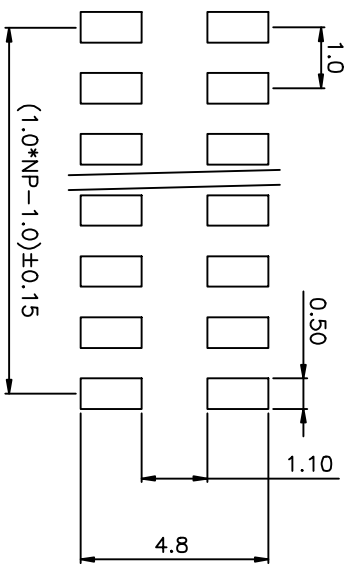
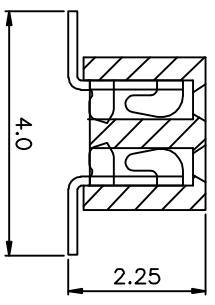
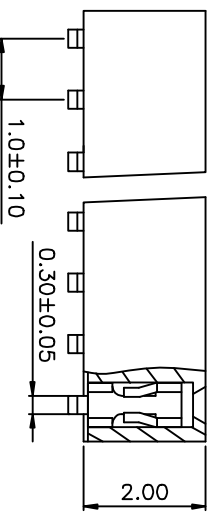
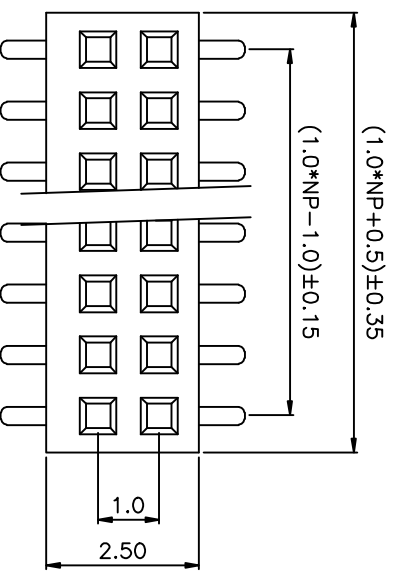

PCB LAYOUT

STANDARD TOLERANCE (EXCEPT SPECIFIED)	ANGLES
LINER	
.0 ±0.30	0.° ±3°
.00 ±0.20	.0° ±2°
.000 ±0.10	.00° ±1°

LDCONN 东莞连大精密制品有限公司 Dongguan Lianda Precision Products Co., LTD		TITLE PH1.0mm H2.0mm 2XNP SMT Dual row Terminal Header		DRAWN BY Lu Junhui		DATE 18.03.30	
PART NO L302XX-XX2XXXXX		CHECKED BY		APPROVED BY		PAGE 1/1	
DRAWING NO		SCALE 1:1		UNIT mm		SIZE A4	